

# Martin® Slider Cradle

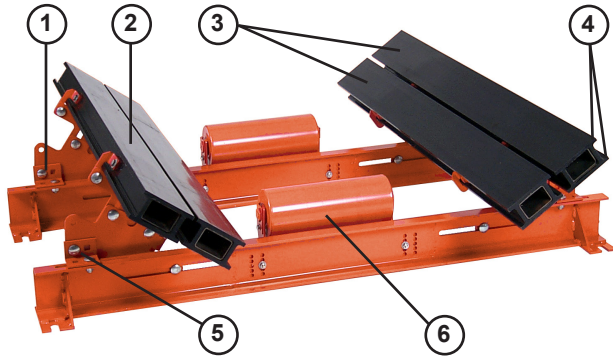

Installed under the skirtboard of a transfer point, [Martin® Slider Cradles](#) support the edges of the belt to eliminate sag. These cradles prevent transfer point spillage by stabilizing the belt's path and allow the effective sealing of the belt edge. Cradles are available with high-performance UHMW or Stainless Steel Bars to match application requirements.

## BENEFITS

- **Stabilizes Belt Path**  
Cradles support belt edges, allowing effective seal.
- **Protects the Belt**  
Cradles eliminate pinch points where trapped material can gouge the belt.
- **Low Friction**  
Belt glides over low friction UHMW or stainless steel bars with low drive-power consumption of drive power and minimal heat buildup.
- **Double Wear Life**  
Unique "box" design of UHMW bar allows use of both top and bottom surface.
- **Simple to Service**  
To compensate for wear, adjust cradle easily with hand tools. Simple bar change without system disassembly.
- **Cradles to Fit Conditions**  
Cradles adjust to fit any trough angle. Options to meet application requirements.

## NOTES

- Typical bars and cradles are 48 in. (1220 mm) in length. Special lengths are available.
- Martin Engineering recommends the installation of a Martin® Trac-Mount™ Idler set before and after each cradle.
- When installing one or more Martin® Slider Cradles, it is necessary to check for adequate power in the conveyor drive to overcome the additional friction against the belt. Contact Martin Engineering for additional information.
- Martin® Slider Cradles are not recommended for conveyors operating at speeds over 700 fpm (3.5 m/sec) or that are less than 50 ft (15 m) in length. To improve belt support on short conveyors or high-speed belts, contact Martin Engineering.

## FEATURES

- |                                    |  |
|------------------------------------|--|
| 1 Adjustable to match belt trough  | 4 Double the wear life                                       |
| 2 Single-bar or double-bar designs | 5 Adjustable for wear  |
| 3 Low-friction bars                | 6 Center support rollers<br>(Standard on double-bar cradles) |

## SELECTION GUIDE

Belt Width	Bars Per Side	Center Rollers
18-24 in. (450-610 mm)	One*	Optional** (24 in. Only)
30-42 in. (700-1100 mm)	One*	Optional**
48-96 in. (1200-2400 mm)	Two	Included

\* Double-bar cradles are recommended for all applications where belt speed is greater than 500 ft/min (2.5 m/sec) or where the installation is adjacent to a loading zone with high impact levels.

\*\* Center rollers are recommended for applications where capacity is over 450 tph (408 MT/h). Order Support Roller Kit P/N 36725-DXXXX.

## MARTIN® SUPPORT BAR

Bar Materials	UHMW Polyethylene
Bar Dimensions (Typical; Other lengths are available)	Height: 2.9 in (72 mm) Width: 5.0 in (127 mm) Length: 48 in (1220 mm)
Coeffecient of Friction	0.5
Specific Gravity	0.94
Durometer	62 (Shore D)
Service Temperature	-20° to 140°F (-29° to 60°C)
Replacement Bar	P/N 31275

# TECHNICAL DATA SHEET

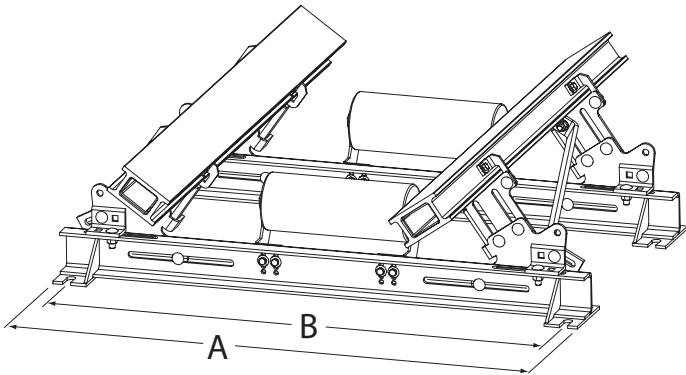

**Single-Bar Cradle with Optional Rollers**  
(30-42 in / 700-1100 mm)

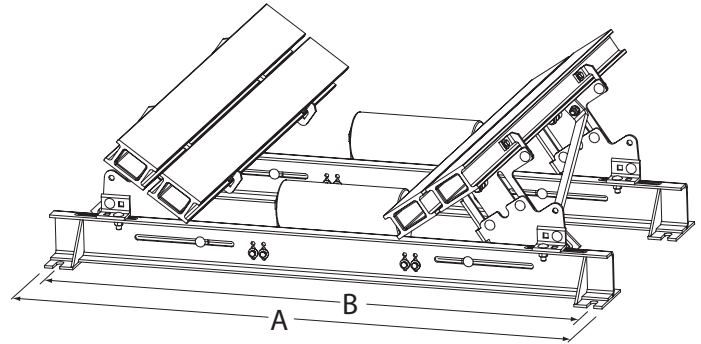

**Double-Bar Cradle**

## DIMENSIONS & ORDER INFORMATION

P/N	Belt Width in (mm)	Stringer Style	Stringer Width (A) in (mm)	Mounting Centers (B) in (mm)	Shipping Weight lb (kg)
<b>Single-Bar Cradles</b>					
36700-18S 36700-18W	18 (350-500)	Standard Base Wide Base	29.5 (750) 35.5 (902)	27 (686) 33 (838)	110 (49.9) 114 (51.7)
36700-24S 36700-24W	24 (500-650)	Standard Base Wide Base	35.5 (902) 41.5 (1054)	33 (838) 39 (991)	120 (54.4) 126 (57.2)
36700-30S 36700-30W	30 (650-800)	Standard Base Wide Base	41.5 (1054) 47.5 (1207)	39 (991) 45 (1143)	135 (61.2) 141 (64.0)
36700-36S 36700-36W	36 (800-1000)	Standard Base Wide Base	47.5 (1207) 53.5 (1359)	45 (1143) 51 (1295)	141 (64.0) 147 (66.7)
36700-42S 36700-42W	42 (1000-1200)	Standard Base Wide Base	53.5 (1359) 59.5 (1511)	51 (1295) 57 (1448)	156 (70.8) 163 (73.9)
<b>Double-Bar Cradles</b>					
36700-48S 36700-48W	48 (1200-1400)	Standard Base Wide Base	59.5 (1511) 65.5 (1664)	57 (1448) 63 (1600)	254 (115.2) 261 (118.4)
36700-54S 36700-54W	54 (1400-1600)	Standard Base Wide Base	65.5 (1664) 71.5 (1816)	63 (1600) 69 (1753)	276 (125.2) 283 (128.4)
36700-60S 36700-60W	60 (1600-1800)	Standard Base Wide Base	71.5 (1816) 77.5 (1969)	69 (1753) 75 (1905)	298 (135.2) 306 (138.8)
36700-72S 36700-72W	72 (1800-2000)	Standard Base Wide Base	83.5 (2121) 89.5 (2273)	81 (2057) 87 (2210)	329 (149.2) 340 (154.2)



**Martin Engineering USA**  
One Martin Place  
Neponset, IL 61345-9766 USA  
800 544 2947 or 309 852 2384  
Fax 800 814 1553  
www.martin-eng.com

**COMPANY WITH  
QUALITY SYSTEM  
CERTIFIED BY DNV GL  
= ISO 9001 =**

**Problem Solved™ GUARANTEED!**

Form No. L3298-03-01/23  
© Martin Engineering Company 1997, 2023