

Martin® Vibrotor™ CCR Vibrator

This simple, long-lasting [Martin® Vibrotor™ CCR Vibrator](#) provides effective high-frequency vibration at an economical price. Apply to hoppers, bins, railcars, chutes, molds, screens, and tables to keep materials flowing as they should. Also great for use in pre-cast concrete applications.



BENEFITS

- **Unique**
Generates multiple vibrations on each orbit.
- **Bearing-Free Design**
Eliminates wear problems and extends service life.
- **Portable or Permanent Mount**
Mount options include weldable cradle lug bracket, cradle lug wedge bracket, cradle lug clamp mount, or cradle lug bolt mount.

SPECIFICATIONS

Model	P/N	Unbalance	
		lb-in.	kg-mm
CCR-4400	29725	0.441	5.1
CCR-5500	28848	1.262	14.5
CCR-6500	29905	2.344	27.0

PERFORMANCE DATA

Model	20 psi (1.38 bar)			40 psi (2.76 bar)			60 psi (4.14 bar)			80 psi (5.52 bar)			Max. lb (kg) material in slope of bin*
	Speed VPM	Force lb (kg)	Flow cfm (L/min)	Speed VPM	Force lb (kg)	Flow cfm (L/min)	Speed VPM	Force lb (kg)	Flow cfm (L/min)	Speed VPM	Force lb (kg)	Flow cfm (L/min)	
CCR-4400	7200	649 (294)	35 (991)	11,500	1655 (751)	53 (1501)	13,500	2281 (1035)	65 (1841)	15,000	2816 (1277)	73 (2067)	28,160 (12,773)
CCR-5500	6600	1560 (708)	32 (906)	10,000	3582 (1625)	42 (1189)	12,500	5596 (2538)	55 (1558)	14,000	7020 (3184)	58 (1643)	70,200 (31,843)
CCR-6500	5800	2238 (1015)	25 (708)	8500	4806 (2180)	35 (991)	10,700	7616 (3455)	44 (1246)	12,500	10,395 (4716)	50 (1416)	103,950 (47,152)

* **Rule-of-thumb vibrator sizing:** One pound of vibrator force for every ten pounds of product in the sloped section of the bin content. Mount vibrator as close as possible to material outlet. Reinforce mount area to prevent flexure of bin wall at mount location.

TECHNICAL DATA SHEET

DIMENSIONS

Model	A in. (mm)	B in. (mm)	C in. (mm)	E in. (mm)	F in. (mm)	K*	Weight lb (kg)
CCR-4400	7.08 (179.8)	5.10 (129.6)	6.67 (169.5)	3.50 (89.0)	2.94 (74.6)	0.50	16 (7)
CCR-5500	9.63 (244.5)	9.50 (241.2)	6.75 (171.5)	3.39 (86.0)	4.13 (105)	0.50	32 (14)
CCR-6500	9.63 (244.5)	9.50 (241.2)	6.75 (171.5)	3.39 (86.0)	4.13 (105)	0.50	36 (16)

*Hose I.D. Size

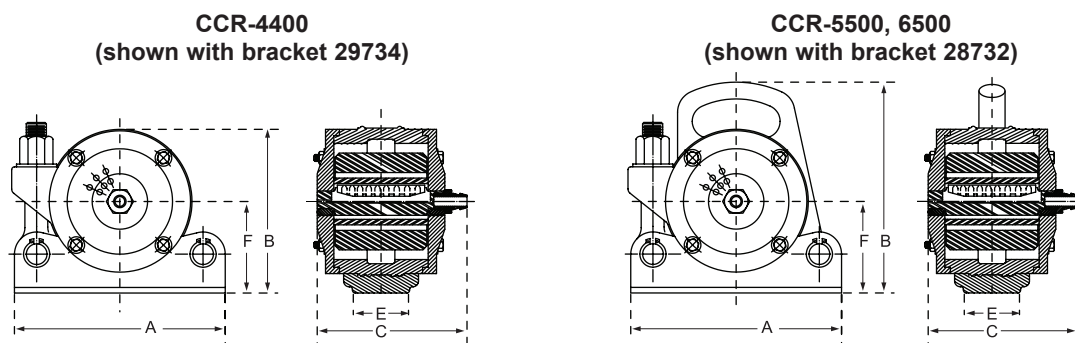

CRADLE LUG MOUNTS

Model	Wedge Mount	Clamp Mount	Standard	Bolt Mount
CCR-4400	n/a	n/a	29734	n/a
CCR-5500	29551	22817	28732	221151
CCR-6500	29551	22817	28732	221151

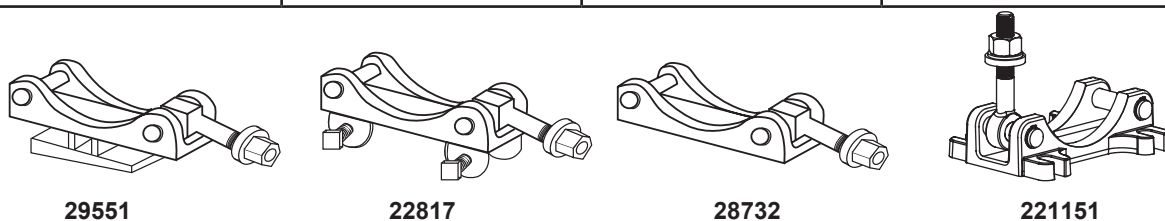

ACCESSORIES

P/N	Description
12735	Female Wedge Bracket
39504	Control Line Kit
14824	Ball Valve 1/2" NPT
14760	Filter, Regulator, Lubricator Combination, 1/2" NPT
14766	Air Motor Oil (qt)
38902	On/Off Cycle Timer 115/1/60
36343-NC	Solenoid Valve 115/1/60, 1/2" NPT
36528-NC	Solenoid Valve NC 24V DC Pilot Operate



Martin Engineering USA

One Martin Place
 Neponset, IL 61345-9766 USA
 800 544 2947 or 309 852 2384
 Fax 800 814 1553
 www.martin-eng.com

COMPANY WITH
 QUALITY SYSTEM
 CERTIFIED BY DNV GL
 = ISO 9001 =

Problem Solved™ GUARANTEED!

Form No. L2581-08/23
 © Martin Engineering Company 2002, 2023