

ASSEMBLY PART NO.	DIM "A"	DIM "B"	DIM "C"	DIM "D"	BLADE QTY	TENS REQUIRED PRESS PSI [BAR]
DT2H-18X12XXXX	12.00 [305]	27.00 [686]	36.16 [918]	49.50 [1257]	2	13 [0.90]
DT2H-18X18XXXX	18.00 [457]	27.00 [686]	36.16 [918]	49.50 [1257]	3	13 [0.90]
DT2H-24X18XXXX	18.00 [457]	33.00 [838]	42.16 [1071]	55.50 [1410]	3	16 [1.10]
DT2H-24X24XXXX	24.00 [610]	33.00 [838]	42.16 [1071]	55.50 [1410]	4	16 [1.10]
DT2H-30X24XXXX	24.00 [610]	39.00 [991]	48.16 [1223]	61.50 [1562]	4	18 [1.24]
DT2H-30X30XXXX	30.00 [762]	39.00 [991]	48.16 [1223]	61.50 [1562]	5	18 [1.24]
DT2H-36X30XXXX	30.00 [762]	45.00 [1143]	54.16 [1376]	67.50 [1715]	5	20 [1.38]
DT2H-36X36XXXX	36.00 [914]	45.00 [1143]	54.16 [1376]	67.50 [1715]	6	20 [1.38]
DT2H-42X36XXXX	36.00 [914]	51.00 [1295]	60.16 [1528]	73.50 [1867]	6	23 [1.59]
DT2H-42X42XXXX	42.00 [1067]	51.00 [1295]	60.16 [1528]	73.50 [1867]	7	23 [1.59]
DT2H-48X42XXXX	42.00 [1067]	57.00 [1448]	66.16 [1680]	79.50 [2019]	7	25 [1.72]
DT2H-48X48XXXX	48.00 [1219]	57.00 [1448]	66.16 [1680]	79.50 [2019]	8	25 [1.72]
DT2H-54X48XXXX	48.00 [1219]	63.00 [1600]	72.16 [1833]	85.50 [2172]	8	27 [1.86]
DT2H-54X54XXXX	54.00 [1372]	63.00 [1600]	72.16 [1833]	85.50 [2172]	9	27 [1.83]
DT2H-60X54XXXX	54.00 [1372]	69.00 [1753]	78.16 [1985]	91.50 [2324]	9	29 [2.00]
DT2H-60X60XXXX	60.00 [1524]	69.00 [1753]	78.16 [1985]	91.50 [2324]	10	29 [2.00]
DT2H-66X60XXXX	60.00 [1524]	75.00 [1905]	84.16 [2138]	97.50 [2477]	10	31 [2.14]
DT2H-66X66XXXX	66.00 [1676]	75.00 [1905]	84.16 [2138]	97.50 [2477]	11	31 [2.14]
DT2H-72X66XXXX	66.00 [1676]	81.00 [2057]	90.16 [2290]	103.50 [2629]	11	33 [2.28]
DT2H-84X78XXXX	78.00 [1981]	93.00 [2362]	102.16 [2595]	115.50 [2934]	13	38 [2.62]
DT2H-96X90XXXX	90.00 [2286]	105.00 [2667]	114.16 [2900]	127.50 [3239]	15	42 [2.90]

ITEM	QTY.	DESCRIPTION	PART NUMBER
1	1	DT2H SPLIT TRACK SECONDARY ASM	DT2H-XXXXXXXXXX
2	1	XHD INLINE/REV AIR TENSIONER	37806-A
3	S/C	REPLACEMENT INLINE TC BLADE	36937-T
4	1	DT2H HANGER BRACKET ASSEMBLY	CONTACT MARTIN

S/C = SEE CHART

- NOTES:
- 1) ALL DIMENSIONS ARE GIVEN IN INCHES (MM).
  - 2) ALL DIMENSIONS ARE FOR REFERENCE PURPOSES ONLY.
  - 3) BOLT OR WELD TENSIONER ASSEMBLY IN PLACE. BOLT TENSIONERS WHEN APPLICABLE FOR EASE OF MAINTENANCE AND ACCESSIBILITY.
  - 4) CENTER BLADES ON BELT SURFACE.
  - 5) WHERE EXTREME OR UNUSUAL CONDITIONS EXIST OR SPECIAL MAINFRAME LENGTHS ARE REQUIRED CONSULT MARTIN ENGINEERING FOR ASSISTANCE.
  - 6) REFER TO OPERATOR'S MANUAL M3699 FOR INSTALLATION INSTRUCTIONS.
  - 7) CLEANER MUST BE MOUNTED WITH BLADES PERPENDICULAR TO BELT SURFACE.
  - 8) THE FIRST TWO XX'S IN THE ASM P/N INDICATES BELT WIDTH.
- THE NEXT X INDICATES BLADE TYPE:  
 0 = NO BLADES  
 A = INLINE TUNGSTEN CARBIDE BLADE  
 T = REVERSING TUNGSTEN CARBIDE BLADE  
 U = REVERSING URETHANE BLADE
- THE NEXT TWO XX'S INDICATE BLADE COVERAGE:  
 00 = NO BLADES
- THE NEXT TWO XX'S INDICATE BLADE COLOR:  
 00 = NO BLADES  
 BR = BROWN  
 GR = GREEN  
 OR = ORANGE  
 NB = NAVY BLUE
- THE NEXT X INDICATES MAINFRAME TYPE:  
 P = PAINTED
- THE LAST X INDICATES ACCESSORY OPTIONS:  
 0 = NO TENSIONER  
 A = HEAVY DUTY INLINE/REV AIR TENSIONER  
 S = HEAVY DUTY INLINE/REV SPRING TENSIONER

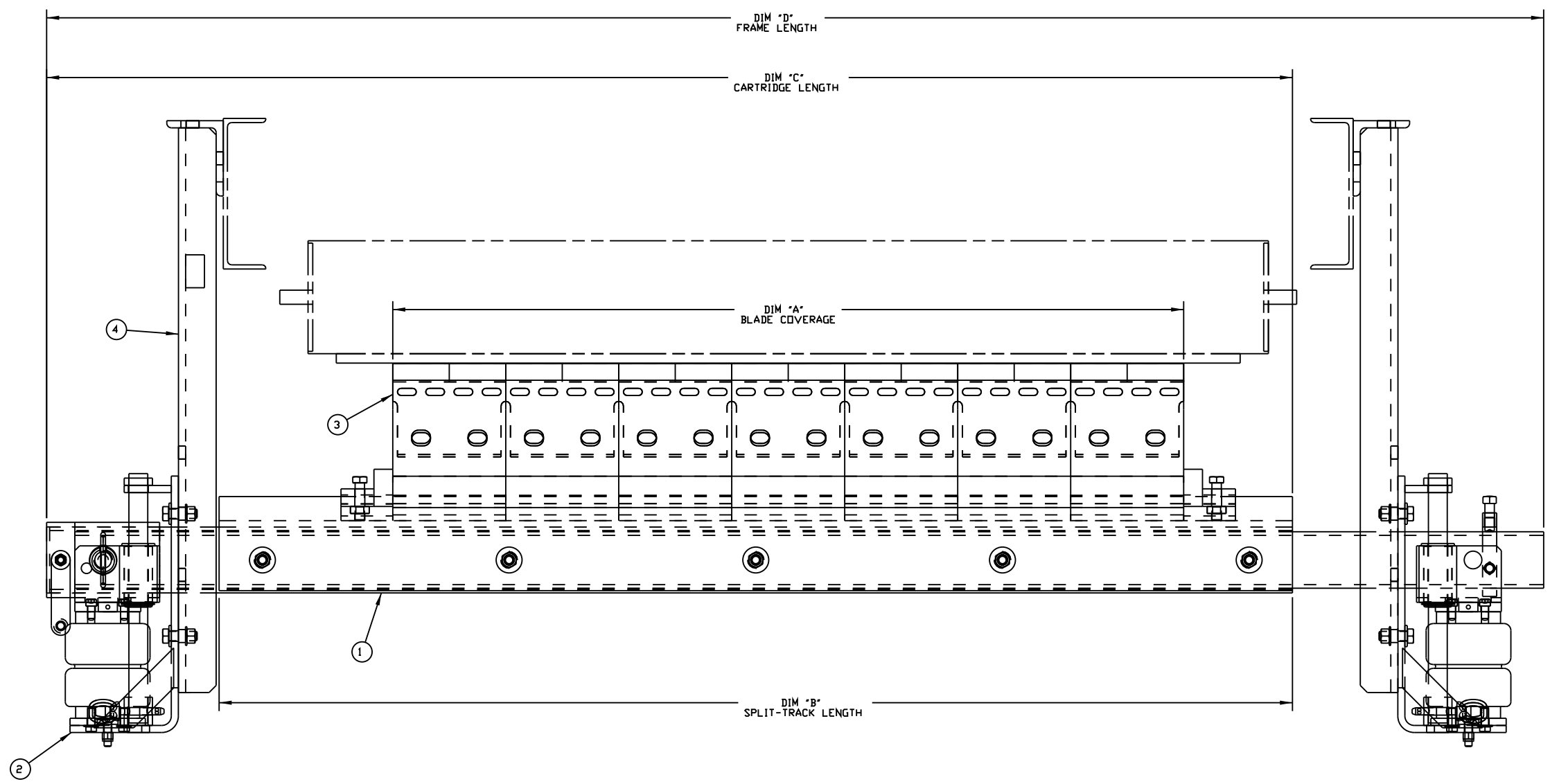
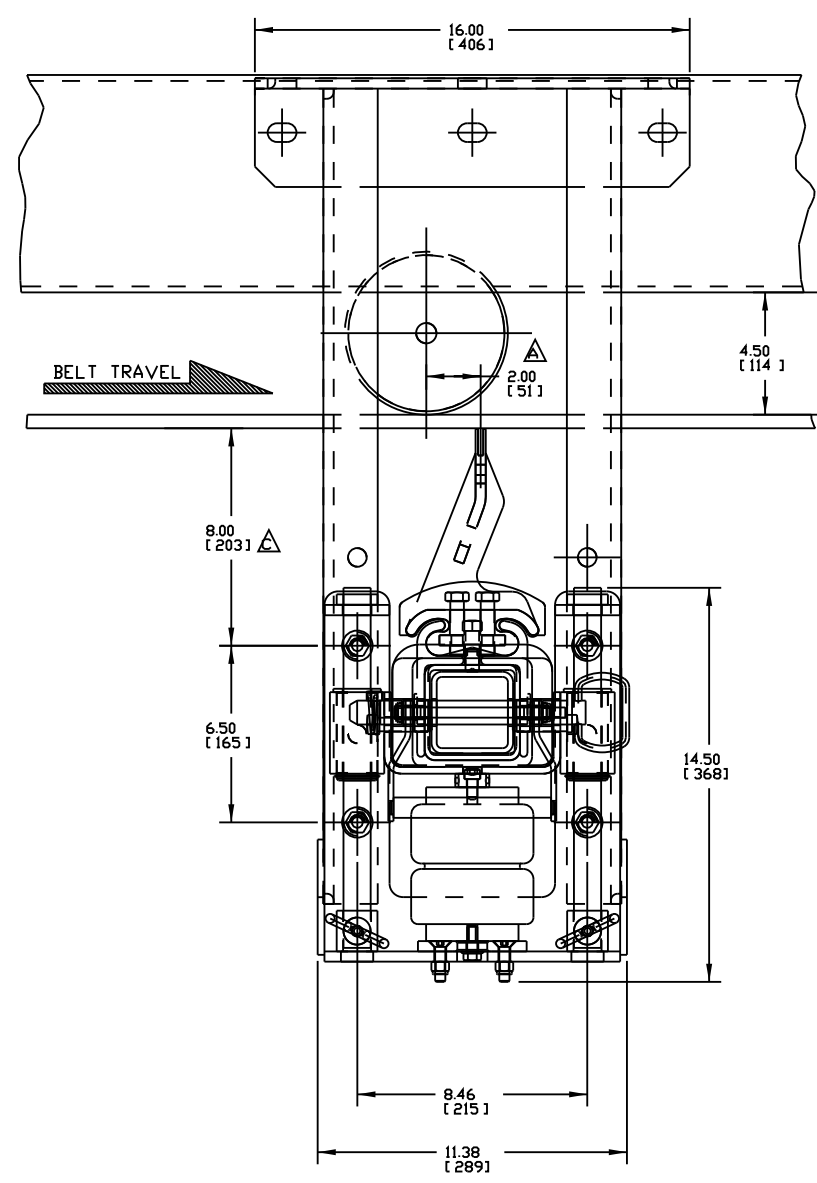

Copyright 2008 Martin Engineering. All rights reserved. Covered by U.S. and Foreign patents pending and issued. R and TM indicate trademarks of Martin Engineering.

**MARTIN ENGINEERING** NEPONSET ILLINOIS USA

NO.	REVISION	DESCRIPTION	ECN	DATE	BY
C	CHGD DIM FROM 594 TO 800		11783	08/10/06	MJB
B	REMOVED REPLACEMENT BLADE CHART. ADDED P/N 36937-T TO BOM. REMOVED P/N'S 36937-AR & 36937-U FROM CHART AND NOTES		11591	02/22/06	RND
A	ADDED DIM 200 (51) / MOVED CLEANER BEHIND ROLL		-----	12/06/05	RND

SALES DRAWING M00644 S50031-A

DATE	BY	APPROVED
12/01/05	RND	JLD
12/01/05	RND	JLD
12/05/05	RND	JLD
9/32		

